

PRODUCT INFORMATION PACKET

Model No: 056B17D11018
Catalog No: C167A
1/2, 1725, DP, 56, 1/60/115/230
Open Drip Proof (ODP)



Regal and Marathon are trademarks of Regal Beloit Corporation or one of its affiliated companies.
©2018 Regal Beloit Corporation, All Rights Reserved. MC017097E



Nameplate Specifications

Output HP	0.50 Hp	Output KW	0.37 kW
Frequency	60 Hz	Voltage	115/230 V
Current	4.6/2.3 A	Speed	1725 rpm
Service Factor	1.25	Phase	1
Efficiency	76.2 %	Duty	Continuous
Insulation Class	B	Design Code	N
KVA Code	K	Frame	56
Enclosure	Drip Proof	Overload Protector	No
Ambient Temperature	40 °C	Drive End Bearing Size	6203
Opp Drive End Bearing Size	6203	UL	Recognized
CSA	Y	CE	Y
IP Code	22		

Technical Specifications

Electrical Type	Capacitor Start Capacitor Run	Starting Method	Across The Line
Poles	4	Rotation	Selective Counterclockwise
Mounting	Rigid base	Motor Orientation	Horizontal
Drive End Bearing	Ball	Opp Drive End Bearing	Ball
Frame Material	Rolled Steel	Shaft Type	NEMA 56
Overall Length	11.47 in	Frame Length	7.50 in
Shaft Diameter	0.625 in	Shaft Extension	1.97 in
Assembly/Box Mounting	F1 Only		
Outline Drawing	A-SS404114-750	Connection Diagram	A-EE9002J-REGAL

This is an uncontrolled document once printed or downloaded and is subject to change without notice. Date Created: 07/02/2018

SS404114

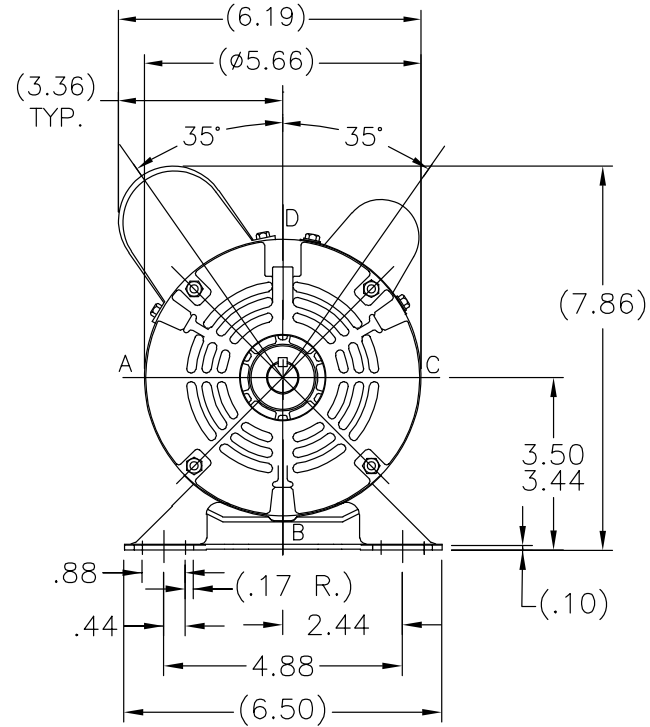
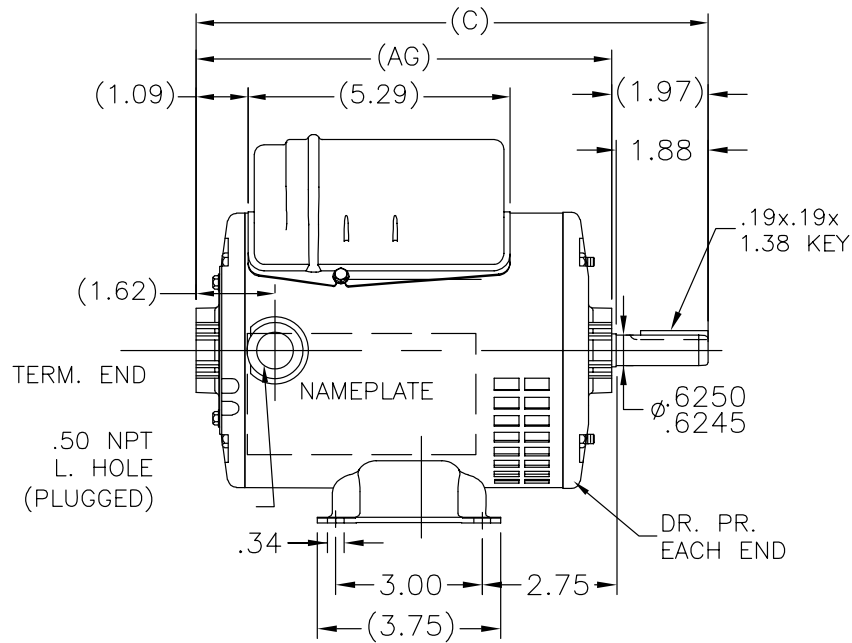

DASH	C	AG	DASH	C	AG
625	10.22	8.25	725	11.22	9.25
650	10.47	8.50	750	11.47	9.50
675	10.72	8.75	775	11.72	9.75
700	10.97	9.00	800	11.97	10.00

		TOLERANCES UNLESS SPECIFIED		DRAWN JAH 11/21/2014	
		DEC.	INCHES	CHK AB 11/21/2014	
		.X	±.1	APPD	
		.XX	±.03	SCALE 1:1	
		.XXX	±.005	REF SS404113/SS75609	
A	CREATED NEW DRAWING	JAH	11/21/2014	AB	.XXXX ±.0005
NO.	REVISION	BY & DATE	CHK	ANG	±7'30"
THIS DRAWING IN DESIGN AND DETAIL IS OUR PROPERTY AND MUST NOT BE USED EXCEPT IN CONNECTION WITH OUR WORK ALL RIGHTS OF DESIGN AND INVENTION ARE RESERVED THIS IS AN ELECTRONICALLY GENERATED DOCUMENT - DO NOT SCALE THIS PRINT		RFP	CAD FILE	SS404114	SIZE
		DIST	WP	A	DRAWING NO. PAGE 1 OF 1 REV.
					SS404114 A

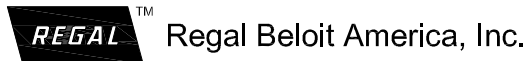

TITLE OUTLINE
48 FRAME

EE9002J

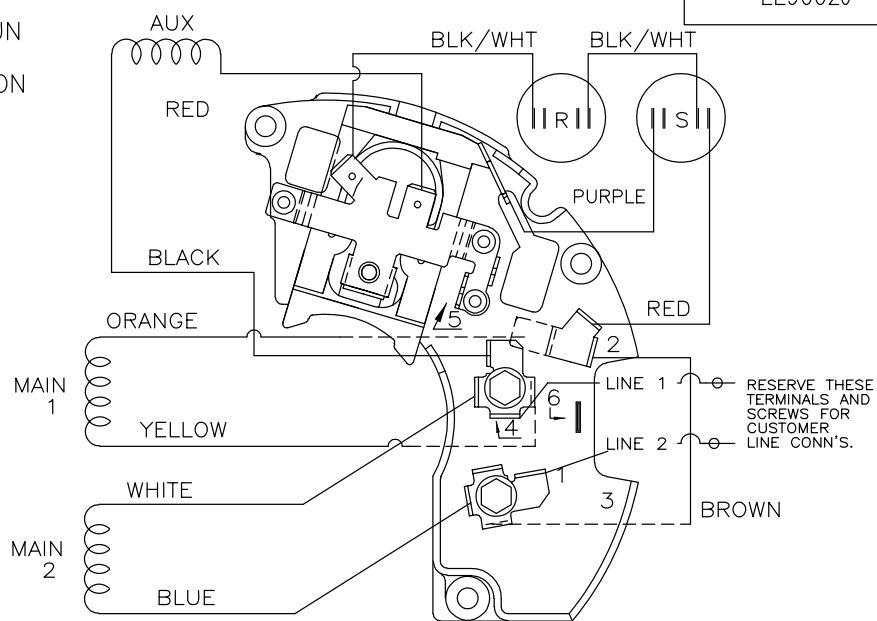
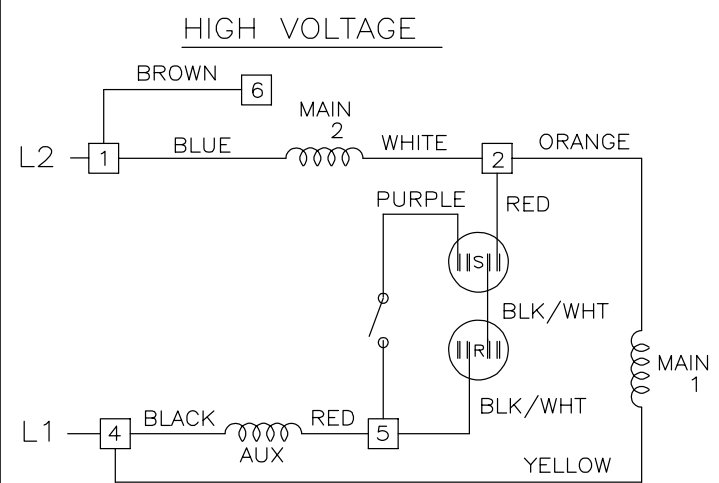
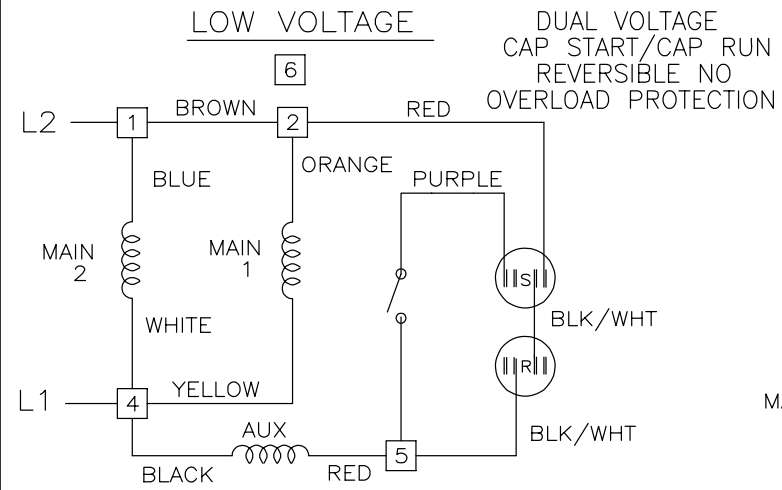

VIEWING TERM END

LOW VOLTAGE CCW ROTATION SHOWN.

FOR HIGH VOLTAGE
CONNECT BROWN TERM 2 TO TERM 6.
CONNECT WHITE TERM 4 TO TERM 2.

TO REVERSE ROTATION EITHER
VOLTAGE INTERCHANGE RED
LEAD WITH BLACK LEAD.

DASH LINES INDICATE LEADS CONNECTED
TO MOTOR SIDE OF SWITCH.

		TOLERANCES UNLESS SPECIFIED			DRAWN SVL 6/17/2013
		DEC.	INCHES		CHK
		.X	± -		APPD
		.XX	± -		SCALE NTS
				TITLE CONNECTION DIAGRAM	REF EE9002J
				48 FR. - DUAL VOLTAGE REVERSIBLE	FMF PR132489
2	TEMPLATE LOGO CHNAGED FROM MARATHON TO DAYTON	KR 05/16/2014	VS .XXXX ± -	MAT'L.	PREV
NO.	REVISION	BY & DATE	CHK ANG ± -	FINISH	
THIS DRAWING IN DESIGN AND DETAIL IS OUR PROPERTY AND MUST NOT BE USED EXCEPT IN CONNECTION WITH OUR WORK ALL RIGHTS OF DESIGN AND INVENTION ARE RESERVED THIS IS AN ELECTRONICALLY GENERATED DOCUMENT - DO NOT SCALE THIS PRINT				RFP	CAD FILE ee9002j
				DIST	SIZE A
				DRAWING NO. EE9002J	PAGE 1 OF 2
					REV. 02

CERTIFICATION DATA SHEET

Model#: 56B17D11018 A WINDING#: BE484110 NONE 3
 CONN. DIAGRAM: A-EE9002J-REGAL ASSEMBLY: F1 ONLY
 OUTLINE: A-SS404114-750

TYPICAL MOTOR PERFORMANCE DATA

HP	KW	SYNC. RPM	F.L. RPM	FRAME	ENCLOSURE	KVA CODE	DESIGN
1/2	.37	1800	1725	56	DP	K	N

PH	Hz	VOLTS	FL AMPS	START TYPE	DUTY	INSL	S.F	AMB°C	ELEVATION
1	60	115/230	4.6/2.3	ACROSS THE LINE	CONTINUOUS	B3	1.25	40	3300

FULL LOAD EFF: 76.2	3/4 LOAD EFF: 73.7	1/2 LOAD EFF: 66	GTD. EFF	ELEC. TYPE	NO LOAD AMPS
FULL LOAD PF: 91.6	3/4 LOAD PF: 89.8	1/2 LOAD PF: 86.1	76.2	CAP START CAP RUN	1.8 / .9

F.L. TORQUE	LOCKED ROTOR AMPS	L.R. TORQUE	B.D. TORQUE	F.L. RISE°C
24.4 LB-FT	35.4 / 17.7	75.6 LB-FT 310	60.4 LB-FT 248	25

SOUND PRESSURE @ 3 FT.	SOUND POWER	ROTOR WK^2	MAX. WK^2	SAFE STALL TIME	STARTS /HOUR	APPROX. MOTOR WGT
0 dBA	10 dBA	0 LB-FT^2	0 LB-FT^2	10 SEC.	0	0 LBS.

*** SUPPLEMENTAL INFORMATION ***

DE BRACKET TYPE	ODE BRACKET TYPE	MOUNT TYPE	ORIENTATION	SEVERE DUTY	HAZARDOUS LOCATION	DRIP COVER	SCREENS	PAINT
STANDARD	STANDARD	RIGID	HORIZONTAL	FALSE	NONE	FALSE	NONE	GRAY (POWDER)

BEARINGS		GREASE	SHAFT TYPE	SPECIAL DE	SPECIAL ODE	SHAFT MATERIAL	FRAME MATERIAL
DE	OPE						
BALL	BALL	MULTEMP SRL	STANDARD 56	NONE	NONE	1144 STRESSPROOF (C-223)	ROLLED STEEL
6203	6203						

THERMO-PROTECTORS				THERMISTORS	CONTROL	SPACE /n HEATERS
THERMOSTATS	PROTECTORS	WDG RTDs	BRG RTDs			
NONE	NOT	NONE	NONE	NONE	FALSE	NONE VOLTS

If Inverter equals NONE, contact factory for further information

*
N
O
T
E
S
*

INVERTER TORQUE: NONE
INV. HP SPEED RANGE: NONE
ENCODER: NONE
NONE NONE
NONE NONE PPR
BRAKE: NONE NONE
NONE P/N NONE
NONE NONE
NONE FT-LB NONE V NONE Hz

DATE: 06/27/2017 04:33:15 AM
 FORM 3531 REV.3 02/07/99
 ** Subject to change without notice.